

Pilot Valves for Air Compressors

Type: ARC

Application

For *On/Off regulation* controlled by the delivery pressure of a compressor.
As *pressure switch* in pneumatic installations.
As a *pilot valve* to activate 2-way valves, spool valves or butterfly valves.

Operation

When the pressure which is to be controlled reaches the upper limit, Inlet E (at bottom of instrument) is connected to Outlet A. The venting hole R is then closed. If the monitoring pressure reaches the lower limit, Outlet A is connected with the venting hole (R). At the same time Inlet E is being closed. Both switching positions are obtained via a snap action movement of the ball (9).

⚠ Attention! Never attempt to disassemble a cylinder whilst under pressure!

Schematic figure

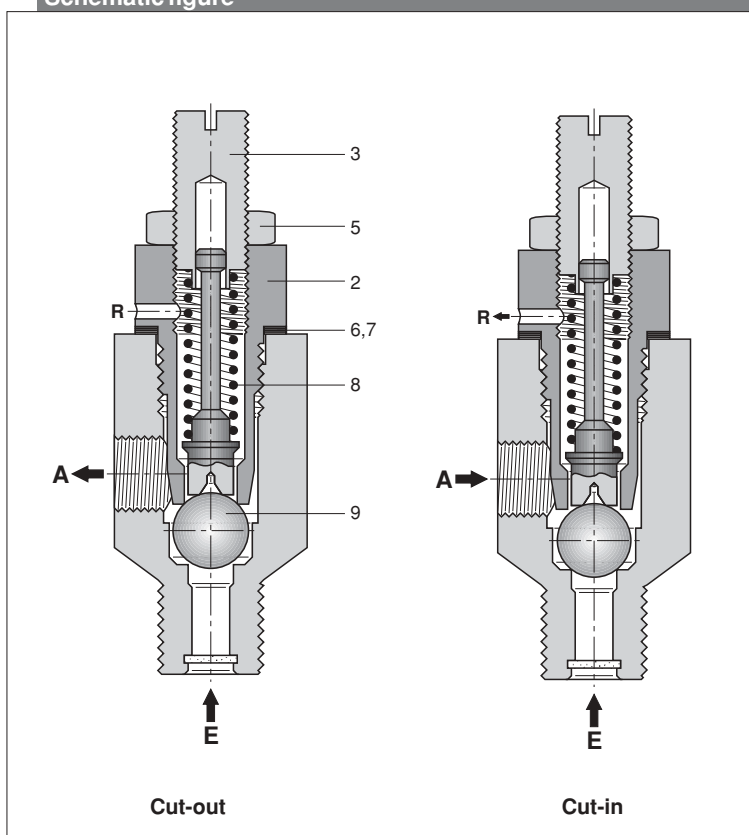

On/Off regulation of compressors:

By reaching the *cut-out pressure* (maximum delivery pressure) the pilot valve activates the unloading devices on the compressor and thereby switches it to zero load. When the pressure falls to the *cut-in level* (minimum delivery pressure), the unloading devices are vented via the pilot valve and the compressor reverts to full load.

Adjustment

Before delivery, the pilot valves are adjusted to the *cut-out* and *cut-in* pressures. Please state the pressures in your order.

Cut-out pressure (upper switching point)

Loose lock nut (5) and turn screw (3) clockwise to raise the pressure. The readjustment range is limited by the execution of the upper part (2) and the spring (8).

Cut-in pressure (lower switching point)

Adjustment via differential pressure between cut-out and cut-in pressure (= *cut-out pressure minus cut-in pressure*). The differential pressure between upper and lower switching point is increased by removing some of the shims, (6) or (7). The *cut-out* pressure (upper switching point) has to be readjusted. The readjustment range is limited by the recommended lift of the ball (9) (0.2 to 1 mm).

Readjustment check:

After each readjustment both upper and lower switching points have to be checked. If the pilot valve shows a shift of the adjusted settings due to strong external vibrations, readjust it on the running compressor..

Ordering details

Type, Cut-out/Cut-in pressure (Accessories).

Executions

All pressures quoted in bar gauge

Working pressure range	European execution Withworth thread (europ. standard)	American execution NPTF/NPSF thread (US-standard)
cut-out pressure 2 - 10 bar (g)	ARC-E10	ARC-A10
10 - 30 bar (g)	ARC-E30	ARC-A30

HOERBIGER KOMPRESSORTECHNIK GMBH

Im Forchet 5 • D-86956 Schongau
Phone +49 (0)8861-210-0 • Fax +49 (0)8861-210-3273
E-mail: rcc@hks.hoerbiger.de • www.hoerbigerkompresortechnik.de

R102E

A1R102E12DAC002



HOERBIGER

Details

Type	Fig.1 Fig.2	ARC-E10 ARC-A10	ARC-E30 ARC-A30
Nominal diameter DN	mm	6	
Max. working pressure PS	bar (g)	10	30
Design		3/2 way valve (ball valve)	
Operating pressure range	bar (g)	2 to 10	≥ 10 to 30
Differential pressure (cut-out pressure minus cut-in pressure) ¹⁾	bar (g)	Diagram 1	Diagram 2
Reproducibility of adjusted pressures	%	± 2 of actual cut-out pressure	
Volume flow V_N	m ³ /h	4.5 at 10 bar (g)	
Maximum Volume of unloader gear connected to Outlet A (recommended)	cm ³	up to 500	
Medium		oily pressurized air, filtered • recommended compressed air quality according to DIN ISO 8573-1, class 5 Reference oil: see www.hoerbigerkompresortechnik.de	
Ambient temperature, Air temperature	°C	up to +200	
Connections		see figs. 1 and 2	
Installation attitude		optional	
Standard materials		Brass, corrosion-resistant steel	
Weight	kg	0.16	

¹⁾ We shall select the optimum combination of components for the requested cut-out/cut-in pressure. For both ranges shown in diagrams 1, 2 and 3, several combinations of components can be chosen.

Pressure differential ARC-.10

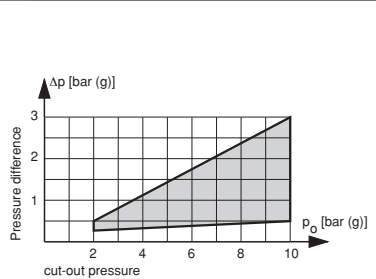

Diagram 1

Pressure differential ARC-.30

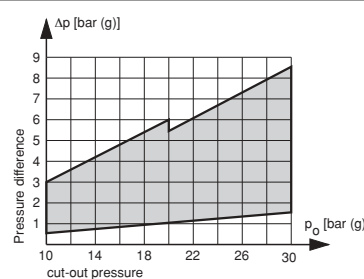

Diagram 2

Adaptors

G1/8 for European execution (ARC-E) can be supplied if no screw connection with short thread is available. For American executions ARC-A screw connections with tapered NPTF thread are used without adaptors.

Other ARC pilot valves

Types ARC-A and ARC-T without hand-unloading device, other customer specific types upon request.

Dimensions (mm)

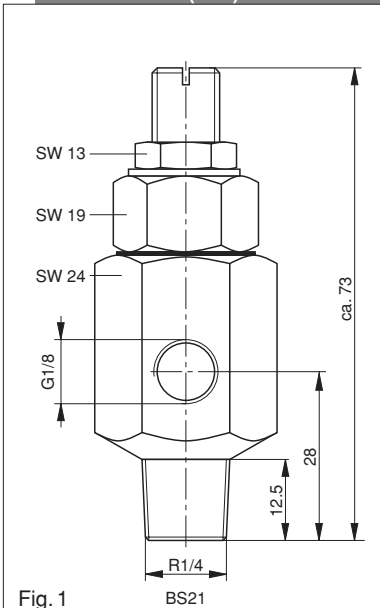

Fig. 1

Dimensions (in)

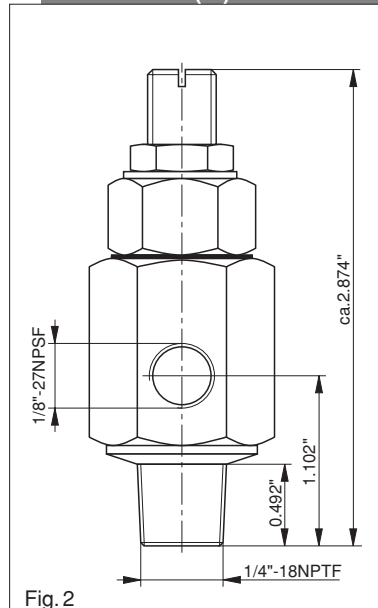

Fig. 2

HOERBIGER can not grant any warranty for the correctness of technical or other datas in catalogues, brochures and other printed material. HOERBIGER reserves the right to alter its products without notice. This also applies to products already on order provided that such alternations can be made without subsequential changes being necessary in specifications already agreed.